

T60xDFH-4 and T60xDFH-4+PIR Series Thermostat Controllers with Dehumidification and Occupancy Sensing Capability

Installation Instructions

Part No. 24-9890-951, Rev. —
Issued October 15, 2009

T601DFH-4, T602DFH-4, T603DFH-4, T604DFH-4, T605DFH-4,
T601DFH-4+PIR, T602DFH-4+PIR, T603DFH-4+PIR, T604DFH-4+PIR, T605DFH-4+PIR

Applications

The T60xDFH-4 and T60xDFH-4+PIR Series Thermostat Controllers provide control of two- or four-pipe fan coils, cabinet unit heaters, or other equipment. These thermostat controllers provide on/off, floating, or proportional 0 to 10 VDC control outputs; three speeds of fan control; and dehumidification capability. The T60xDFH-4+PIR Series Thermostat Controllers have occupancy sensing capability built into the device. These are stand-alone devices that maximize up to 30% energy savings in high-energy usage light commercial buildings, such as schools and hotels, during occupied times by using additional Stand-By setpoints. See the [Occupancy Sensor Operation – T60xDFH-4+PIR Series Thermostat Controllers](#) section for more information.

The non-programmable T60x Series Thermostat Controllers provide the user access to parameters such as system mode, fan mode, and temperature setpoints. Additionally, the T60x Series has over 20 configurable parameters enabling the thermostat controllers to adapt to a variety of applications.

All T60x Series Thermostat Controllers use an intuitive, plain text, menu-driven backlit display that makes setup and operation quick and easy. The T60x Series also employ a unique, Proportional-Integral (PI) time-proportioning algorithm that virtually eliminates temperature offset associated with traditional, differential-based thermostat controllers.

IMPORTANT: The T60xDFH-4 and T60xDFH-4+PIR Series Thermostat Controllers are intended to provide an input to equipment under normal operating conditions. Where failure or malfunction of the thermostat controller could lead to personal injury or property damage to the controlled equipment or other property, additional precautions must be designed into the control system. Incorporate and maintain other devices, such as supervisory or alarm systems or safety or limit controls, intended to warn of or protect against failure or malfunction of the thermostat controller.

North American Emissions Compliance

United States

This equipment has been tested and found to comply with the limits for a Class A digital device pursuant to Part 15 of the FCC Rules. These limits are designed to provide reasonable protection against harmful interference when this equipment is operated in a commercial environment. This equipment generates, uses, and can radiate radio frequency energy and, if not installed and used in accordance with the instruction manual, may cause harmful interference to radio communications. Operation of this equipment in a residential area is likely to cause harmful interference, in which case the user will be required to correct the interference at his/her own expense.

Canada

This Class (A) digital apparatus meets all the requirements of the Canadian Interference-Causing Equipment Regulations.

Cet appareil numérique de la Classe (A) respecte toutes les exigences du Règlement sur le matériel brouilleur du Canada.

Installation

Location Considerations

Locate the T60x Series Thermostat Controller:

- on a partitioning wall, approximately 5 ft (1.5 m) above the floor in a location of average temperature
- away from direct sunlight, radiant heat, outside walls, outside doors, air discharge grills, or stairwells; and from behind doors
- away from steam or water pipes, warm air stacks, unconditioned areas (not heated or cooled), or sources of electrical interference

For integrated Passive Infrared (PIR) models, be sure that the thermostat controller is located centrally, where occupant movement is abundant.

Note: Allow for vertical air circulation to the thermostat controller.

To install the thermostat controller:

1. Use a Phillips-head screwdriver to remove the security screw if it is installed on the bottom of the thermostat controller cover.

Note: Normally, the security screw comes packaged separately in a plastic bag with the thermostat controller. Skip this step if the screw is not installed on the bottom of the cover.

2. Pull the bottom edge of the thermostat controller cover and open the thermostat controller as illustrated in Figure 1.

Note: PIR models have a wiring connection between the cover and the Printed Circuit Board (PCB). This connection allows for proper wiring of the occupancy sensor. Carefully remove the wiring connection from the PCB by pulling up on the connector block. Do not attempt to remove the connector block by pulling on the wires.

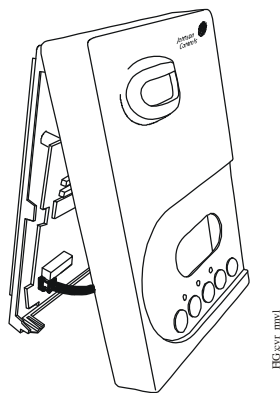

Figure 1: Removing the Thermostat Controller Cover (T60xDFH-4+PIR Model Shown)

3. Carefully pull the locking tabs on the right side of the thermostat controller mounting base and unlock the PCB. Open the PCB to the left as illustrated in Figure 2.
4. Pull approximately 6 in. (152 mm) of wire from the wall and insert the wire through the hole in the thermostat controller mounting base.
5. Align the thermostat controller mounting base on the wall and use the base as a template to mark the two mounting hole locations.

Note: Be sure to position the thermostat controller mounting base so that the arrow on the base points upward to indicate the top of the thermostat controller.

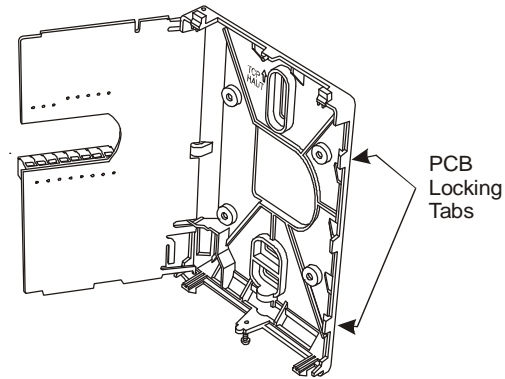

Figure 2: Opening the Thermostat Controller PCB

6. Drill a 3/16 in. (5 mm) hole at each of the two marked locations and tap nylon anchors (included with the thermostat controller) flush to the wall surface.

Note: Other means of anchoring the device may be desired, depending on the wall medium.

7. Position the thermostat controller mounting base on the wall and use the two mounting screws (included with the thermostat controller) to secure the base to the wall surface as illustrated in Figure 3.

Note: Be careful not to overtighten the mounting screws.

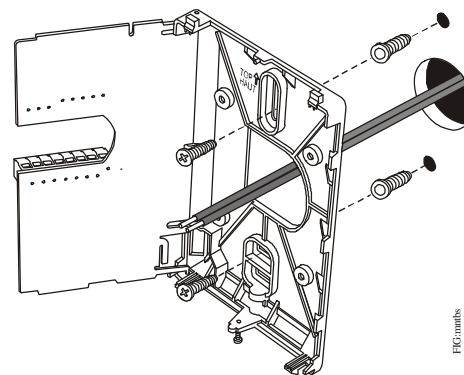

Figure 3: Securing the Thermostat Controller Mounting Base to the Wall

8. Swing the PCB back to the right and carefully snap it into the locking tabs on the thermostat controller mounting base.

9. Remove the screw terminal blocks that are attached to a disposable adhesive. Figure 4 illustrates the locations of the screw terminal blocks on the thermostat controller.

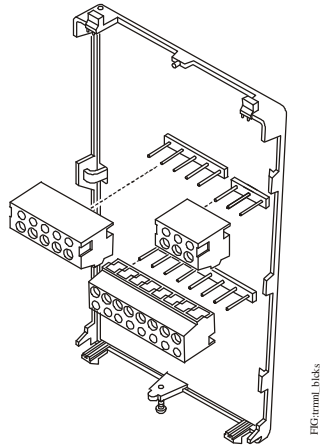

Figure 4: Removing the Screw Terminal Blocks

Wiring

When an existing thermostat controller is replaced, remove and label the wires to identify the terminal functions. When a T60x Series Thermostat Controller is replaced, simply remove the old screw terminal blocks and reinsert them onto the PCB of the replacement thermostat controller.



CAUTION: Risk of Electric Shock.
Disconnect power supply before making electrical connections to avoid electric shock.



CAUTION: Risk of Property Damage.
Do not apply power to the system before checking all wiring connections. Short circuited or improperly connected wires may result in permanent damage to the equipment.

IMPORTANT: Make all wiring connections in accordance with local, national, and regional regulations. Do not exceed the electrical ratings of the T60x Series Thermostat Controller.

To wire the thermostat controller:

1. Strip the ends of each wire a 1/4 in. (6 mm) and connect them to the appropriate screw terminals as indicated in Table 1 and Figure 5 through Figure 9.
2. Carefully push any excess wire back into the wall.

Note: Seal the hole in the wall with fireproof material to prevent drafts from affecting the ambient temperature readings.

3. Reinsert the screw terminal blocks onto the PCB.

Note: If multiple wires are inserted into the terminals, be sure to properly twist the wires together prior to inserting them into the terminal connectors.

4. For PIR models, carefully reattach the PIR connector to the PCB.
5. Reattach the thermostat controller cover to the mounting base (top side first).
6. Use a Phillips-head screwdriver to reinstall the security screw on the bottom of the thermostat controller cover if desired. The security screw comes packaged separately in a plastic bag with the thermostat controller.

Table 1: Terminal Identification (See Figure 5.)

Terminal Number	Terminal Label			Function
	T601DFH-4, T601DFH-4+PIR (On/Off Control)	T602DFH-4, T602DFH-4+PIR, T603DFH-4, T603DFH-4+PIR (On/Off or Floating Control)	T604DFH-4, T604DFH-4+PIR, T605DFH-4, T605DFH-4+PIR (Proportional 0 to 10 VDC Control)	
1	Fan-H	Fan-H	Fan-H	Fan On – High
2	Fan-M	Fan-M	Fan-M	Fan On – Medium
3	Fan-L	Fan-L	Fan-L	Fan On – Low
4	24 V~ Hot	24 V~ Hot	24 V~ Hot	24 VAC from Transformer
5	24 V~ Com	24 V~ Com	24 V~ Com	24 VAC (Common) from Transformer
6	BO5 Aux	BO5 Aux	BO5 Aux	Aux BO (Auxiliary Output)
7	BO5 Aux	BO5 Aux	BO5 Aux	Aux BO (Auxiliary Output)
8	BO3	BO3	Blank	Open Heat
9	Blank	BO4	AO2	Close Heat
10	Blank	BO1	AO1	Open Cool
11	BO2	BO2	Blank	Close Cool
12	BI1	BI1	BI1	Configurable Binary Input 1
13	RS	RS	RS	Remote Room Temperature Sensor
14	Scom	Scom	Scom	Sensor Common
15	BI2	BI2	BI2	Configurable Binary Input 2
16	UI3	UI3	UI3	Configurable Universal Input 3

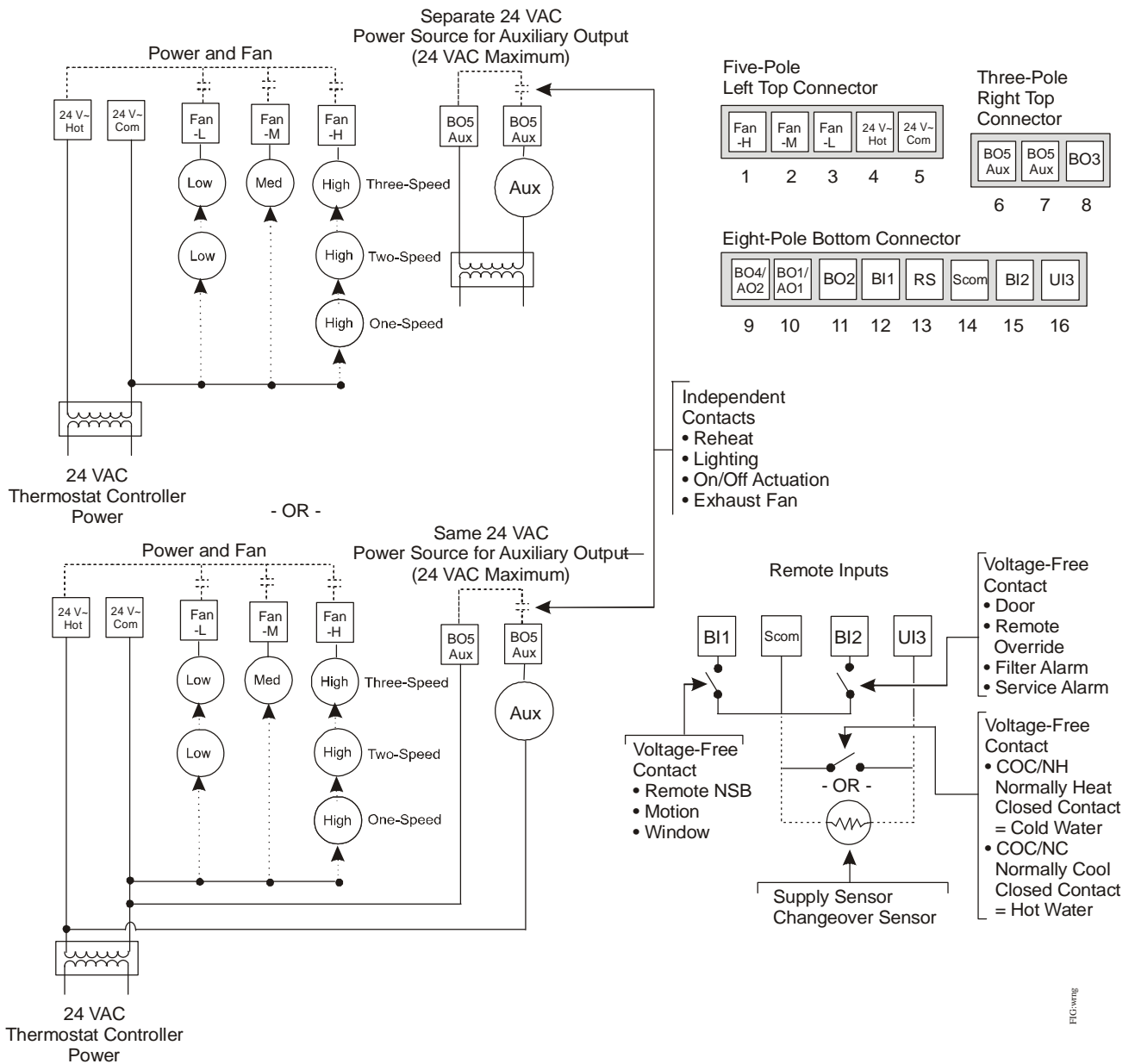

Figure 5: Wiring the T60xDFH-4 or T60xDFH-4+PIR Series Thermostat Controller (See Table 1.)

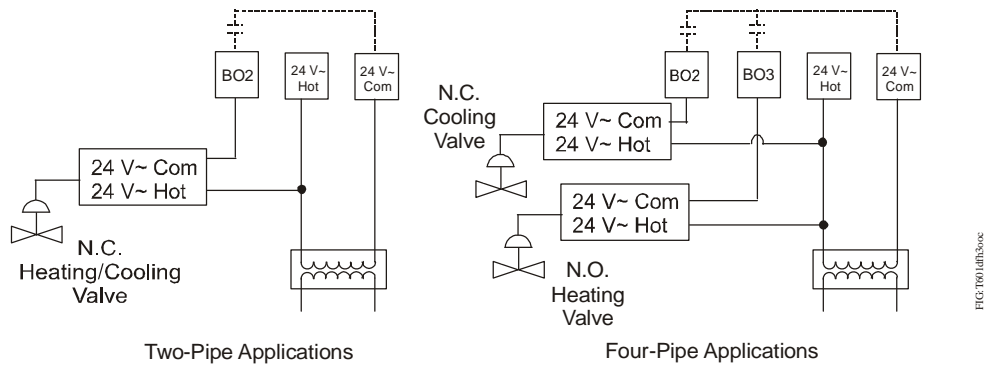

Figure 6: Wiring T601DFH-4 Thermostat Controllers for On/Off Control

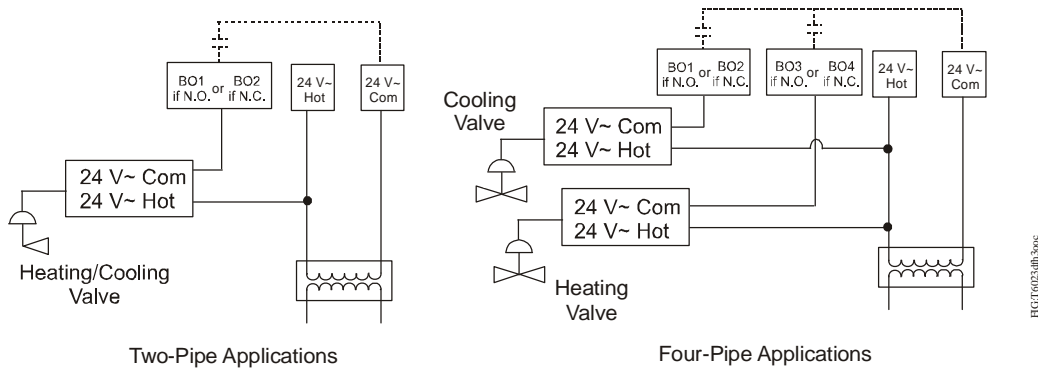

Figure 7: Wiring T602DFH-4 and T603DFH-4 Thermostat Controllers for On/Off Control

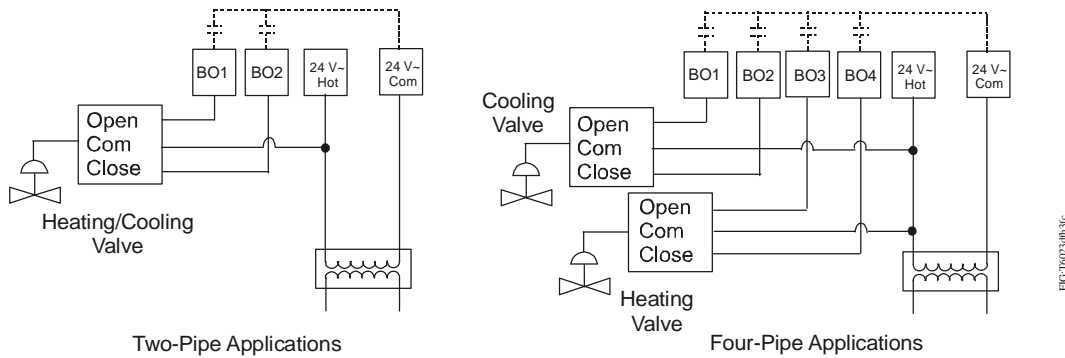

Figure 8: Wiring T602DFH-4 and T603DFH-4 Thermostat Controllers for Floating Control

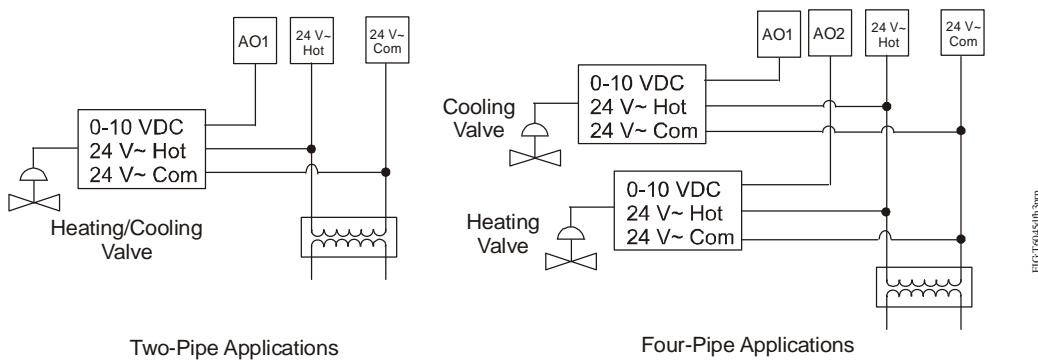

Figure 9: Wiring T604DFH-4 and T605DFH-4 Thermostat Controllers for Proportional Control

Setup and Adjustments

Thermostat Controller Operation Overview

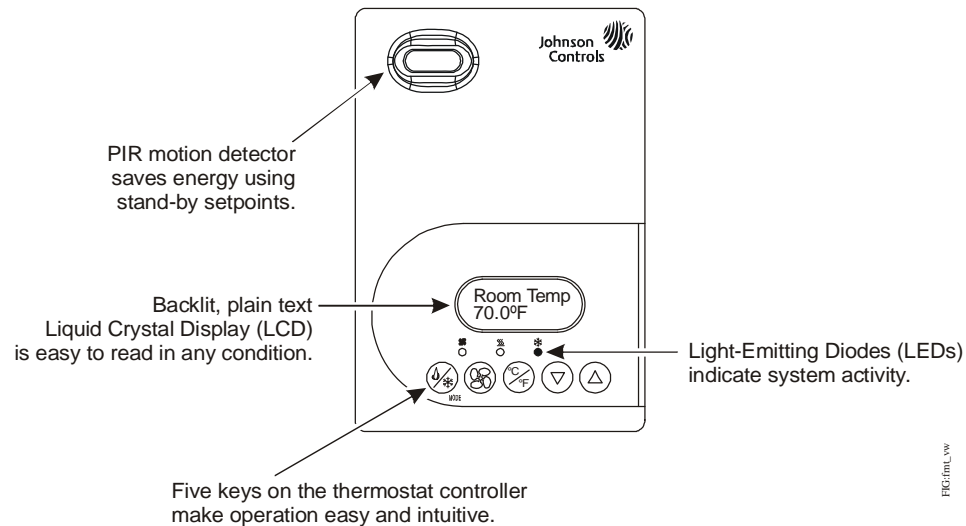

Figure 10: Front Cover of Thermostat Controller (T60xDFH-4+PIR Model Shown)

Thermostat Controller User Interface Keys

The T60x Series Thermostat Controller user interface consists of five keys on the front cover (as illustrated in Figure 10). The function of each key is as follows:



- Use the **MODE** key to toggle among the system modes available, as defined by selecting the appropriate operation sequence in the Installer Configuration Menu (for example, Off, Heat, Cool, Auto).
- Use the **FAN** key to toggle among the fan modes available, as defined by selecting the appropriate fan menu options defined in the Installer Configuration Menu (for example, Low, Med, High, Auto).
- Use the **°C/°F** key to change the temperature scale to either Celsius or Fahrenheit and allow access to the Installer Configuration Menu. See the [Configuring the T60xDFH-4 and T60xDFH-4+PIR Series Thermostat Controller](#) section.
- Use the **UP/DOWN** arrow keys to change the configuration parameters and to activate a setpoint adjustment.

Backlit LCD

The T60x Series Thermostat Controllers include a 2-line, 8-character backlit display. Low-level backlighting is present during normal operation, and it brightens when any user interface key is pressed. The backlight returns to low level when the thermostat controller is left unattended for 45 seconds.

LEDs

Three LEDs are included to indicate the fan status, call for heat, or call for cooling:

- The fan LED  is on when the fan is on.
- The heat LED  is on when heating is on.
- The cool LED  is on when cooling is on.

Integrated PIR Sensor – T60xDFH-4+PIR Series Thermostat Controllers

The integrated PIR sensor allows for automatic switching between fully adjustable Occupied and Stand-By temperature setpoints without user interaction. This feature generates incremental energy savings during scheduled occupied periods while the space is unoccupied.

Status Display Menu

The Status Display Menu is displayed during normal thermostat controller operation. This menu continuously scrolls through the following parameters:

- Room Temperature (All Models) and Humidity (T603DFH-4 and T605DFH-4 Models)

Note: For models with dehumidification capability, the default setting is no humidity reading on the display (%RH disp parameter is set to **off**). The %RH disp parameter must be set to **on** to display the current humidity reading.

- System Mode
- Schedule Status (Occupied/Unoccupied/Override/Stand-By [PIR Models])
- Applicable Alarms – The backlight lights up as an alarm condition is displayed.

Note: An option is available within the Installer Configuration Menu to lock out the scrolling display and show only the **Room Temperature** parameter.

Dehumidification Operation – T603DFH-4 and T605DFH-4 Thermostat Controller Models

Dehumidification activates when the room humidity is above the adjustable humidity setpoint as sensed by the integral humidity sensor.

Note: Dehumidification operation functions only in the Cooling mode; dehumidification operation does not function in either the Off or the Heating mode.

The minimum deadband between the Heating and Cooling setpoints is adjustable from 2.0F°/1.0C° to 5.0F°/2.5C°, as defined by the **Deadband** parameter in Table 4. If the room temperature resides in the deadband between the Heating and Cooling setpoints:

- the thermostat controller forces the fan to low speed
- the chilled water valve opens to the specified maximum value set by **CoolMax**
- the thermostat controller stages Heating to maintain the room temperature at the Cooling setpoint, as sensed by the thermostat controller

If the room temperature falls below the result of the formula **1 + Cooling Setpoint – Deadband**, then the thermostat controller disables dehumidification operation.

If the thermostat controller is in Cooling demand:

- the chilled water valve opens to 100%
- the thermostat controller stages Heating to maintain the room temperature at the Cooling setpoint, as sensed by the thermostat controller

If the thermostat controller is in Cooling demand and the room temperature rises 2F°/1C° above the Cooling setpoint, the thermostat controller automatically disables dehumidification operation. Likewise, if the thermostat controller is in Cooling demand and the room temperature falls below the current Heating setpoint, the thermostat controller disables dehumidification operation.

Occupancy Sensor Operation – T60xDFH-4+PIR Series Thermostat Controllers

A T60xDFH-4+PIR Series Thermostat Controller (or a T60xDFH-4 Series Thermostat Controller equipped with a PIR accessory cover) provides advanced occupancy logic.

Note: The PIR strategy is an occupied strategy. If the thermostat controller is programmed to be Unoccupied, the PIR function does not have an effect on the occupancy strategy.

The thermostat controller automatically switches occupancy levels from Occupied to Stand-By and Unoccupied as required, when local movement is sensed.

Occupancy sensing is enabled only if a PIR cover is installed on the thermostat controller (PIR models) or if a remote input is configured as a remote PIR sensor (**MotionNO** or **MotionNC**).

PIR Warm-Up Period

When a PIR cover is used and a thermostat controller is powered up, there is a 1-minute warm-up period before any local movement can be detected and acknowledged by the PIR sensing device. The local status LEDs for the PIR function are not active, and the sensor is in Stand-By mode for the 1-minute period. The PIR functionality and local movement status LEDs are activated after the 1-minute warm-up period has elapsed after the initial powering of the thermostat controller. If movement is present, the mode changes to Occupied.

PIR Diagnostic LEDs

The diagnostic LEDs inside the PIR lens brighten when movement is detected within the first 30 minutes after powerup. The LEDs do not light up or brighten after the initial 30-minute period.

Setpoints

The Stand-By setpoints are under the same limitations and restrictions as the Occupied and Unoccupied setpoints. Stand-By setpoints reside between the corresponding Occupied and Unoccupied setpoint values.

The installer must be certain that the difference between the Stand-By and Occupied values can be recovered within a timely fashion to ensure occupancy comfort. In addition, the difference between the two values must be large enough to warrant maximum energy savings.

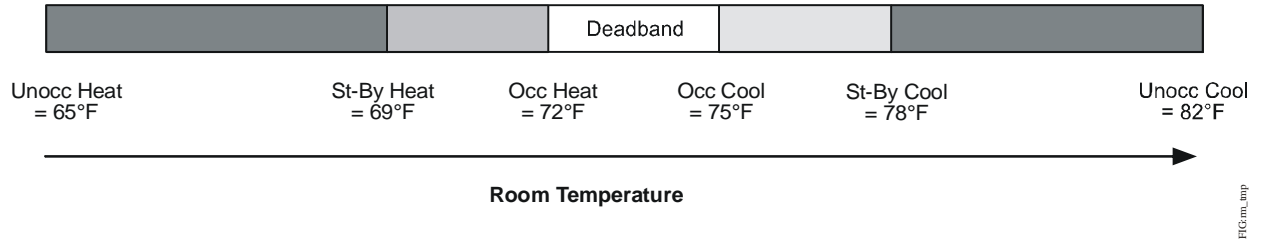

Figure 11: Increasing Room Temperature Setpoints

Hotel and lodging applications can benefit from the addition of an entry door switch wired to one of the binary inputs of the thermostat controller. When a door contact is used and configured, the Stand-By timer and its configuration are no longer active or used. The occupancy toggle between Occupied and Stand-By is then dictated by both the door contact and the PIR sensing device used. If movements are detected by the PIR sensor and the door is closed, the room is considered occupied. The thermostat controller switches back to Stand-By mode only if the door switch toggles open/closed. Motion is ignored when the door switch indicates an open door.

PIR occupancy functionality is dictated by both the Stand-By timer and Unoccupied timer configuration value and movements present in the area.

Unoccupied Timer Disable

It might be preferable for the local area to stay out of Unoccupied mode and always stay at the Stand-By occupancy level when no activity is present. In instances when areas always need to be on Stand-By status, ready to respond to demand at any given point in time, we recommend disabling the Unoccupied timer. When the local PIR occupancy routine is running at the thermostat controller, the zone drifts into Unoccupied mode when the Unoccupied timer is set above its factory default value of 0.0 hours.

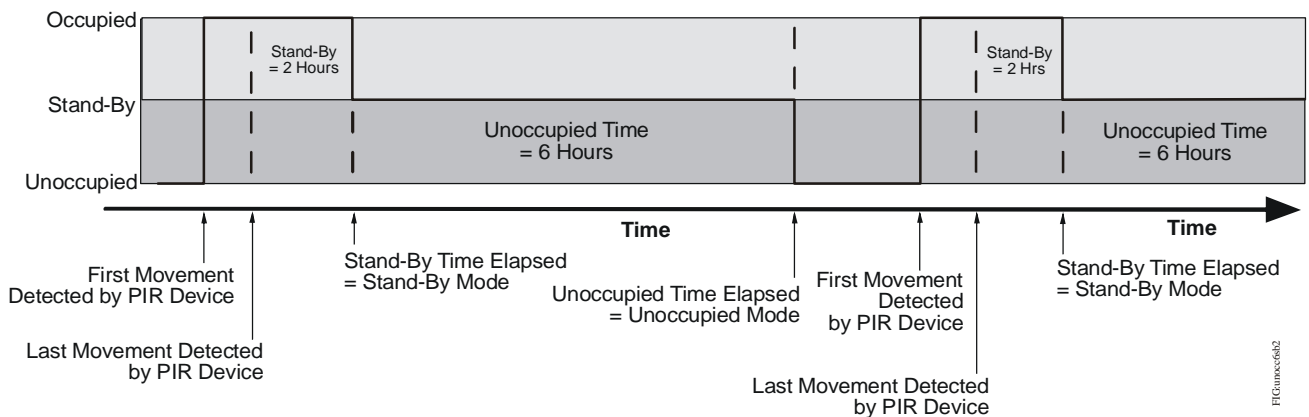

Figure 12: Unoccupied Timer Set to 6 Hours and Stand-By Timer Set to 2 Hours

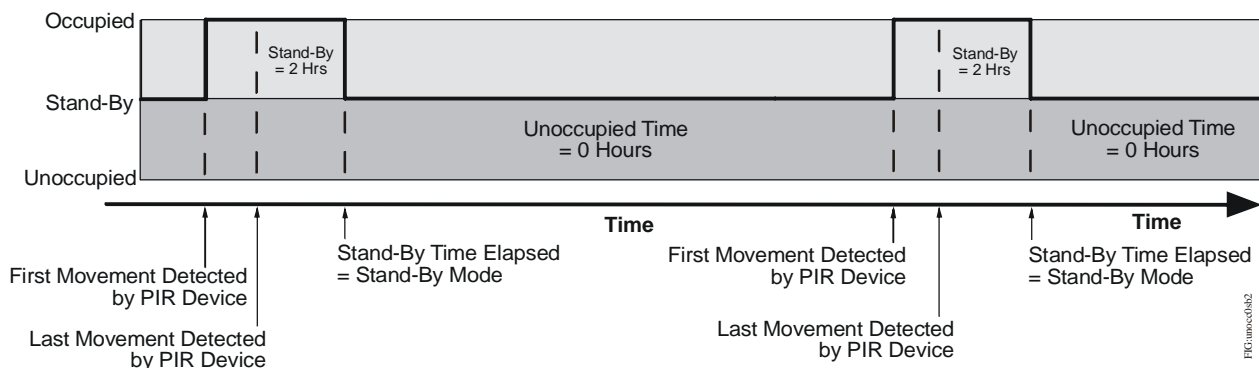

Figure 13: Unoccupied Timer Set to 0 Hours and Stand-By Timer Set to 2 Hours

When the local PIR occupancy routine is running at the thermostat controller, the zone never drifts into Unoccupied mode when the Unoccupied timer is set to its factory default value of 0.0 hours.

Refer to the *T60xDFH-4 and T60xDFH-4+PIR Series Thermostat Controllers with Dehumidification and Occupancy Sensing Capability Application Note (LIT-12011569)* for additional application scenarios using various combinations of occupancy levels and door switches.

Configuring the T60xDFH-4 and T60xDFH-4+PIR Series Thermostat Controller

The T60x Series Thermostat Controller comes from the factory with default settings for all configurable parameters. The default settings are shown in Table 4. To reconfigure the parameters via the thermostat controller, follow the steps in this section.

1. To access the Installer Configuration Menu, press and hold the center key for approximately 8 seconds.

Note: If the **Password** parameter is configured, Password 0 appears on the thermostat controller display indicating that the configured password is required to proceed. Use the **UP/DOWN** arrow keys to indicate the configured password, then press the **MODE** key to proceed through the Installer Configuration Menu parameters.

2. Once the Installer Configuration Menu begins, press and release the center key to scroll through the parameters listed in Table 4.
3. When the desired parameter is displayed, use the **UP/DOWN** arrow keys to choose the desired selection option.

4. Press and release the center key to continue scrolling through the parameters.

Note: Pressing the **FAN** key during configuration restarts the list of displayed parameters at the first parameter listed in Table 4.

When the thermostat controller is in the Installer Configuration Menu and left unattended for approximately 8 seconds, the thermostat controller reverts to the Status Display Menu.

Configuring Inputs BI1, BI2, and UI3

When BI1 and BI2 are configured for an alarm condition, an alarm condition is displayed locally when the input is closed. An alarm message is included on the scrolling Status Display Menu and when the message is displayed, the backlight momentarily lights up.

The UI3 input provides changeover of hot/cold water switching or supply air temperature monitoring at the thermostat controller.

Each input can be configured to the selection options included in Table 4.

Configuring the Sequence of Operation (SeqOpera)

Choose the appropriate sequence of operation using Table 2 or Table 3. The modes presented are user-dependent on the sequence of operation selected. For two-pipe applications using a changeover sensor, choose the selection option **(0): Cooling Only**. Changeover occurs between **Cooling Only** and **Heating Only**. See Figure 14 through Figure 19 for sequence of operation examples.

Table 2: Selection Options for Sequence of Operation in Two-Pipe Applications

Selection Option	Control Curve	Terminal Numbers Used (See Table 1 and Figure 5.)		
		On/Off Control	Floating Control	Proportional 0 to 10 VDC Control
(0): Cooling Only	See Figure 14.	10: Normally Open (N.O.) Cooling 11: Normally Closed (N.C.) Cooling	10: Open Cooling 11: Closed Cooling	10: Proportional Cooling
(1): Heating Only	See Figure 15.	10: N.O. Heating 11: N.C. Heating	10: Open Heating 11: Closed Heating	10: Proportional Heating
(2): Cooling and Reheat	See Figure 16.	6 and 7: Reheat 10: N.O. Cooling 11: N.C. Cooling	6 and 7: Reheat 10: Open Cooling 11: Closed Cooling	6 and 7: Reheat 10: Proportional Cooling
(3): Heating and Reheat	See Figure 17.	6 and 7: Reheat 10: N.O. Heating 11: N.C. Heating	6 and 7: Reheat 10: Open Heating 11: Closed Heating	6 and 7: Reheat 10: Proportional Heating

Table 3: Selection Options for Sequence of Operation in Four-Pipe Applications

Selection Option	Control Curve	Terminal Numbers Used (See Table 1 and Figure 5.)		
		On/Off Control	Floating Control	Proportional 0 to 10 VDC Control
(0): Cooling Only	See Figure 14.	10: N.O. Cooling 11: N.C. Cooling	10: Open Cooling 11: Closed Cooling	10: Proportional Cooling
(1): Heating Only	See Figure 15.	8: N.O. Heating 9: N.C. Heating	8: Open Heating 9: Closed Heating	9: Proportional Heating
(2): Cooling and Reheat	See Figure 16.	6 and 7: Reheat 10: N.O. Cooling 11: N.C. Cooling	6 and 7: Reheat 10: Open Cooling 11: Closed Cooling	6 and 7: Reheat 10: Proportional Cooling
(3): Heating and Reheat	See Figure 17.	6 and 7: Reheat 8: N.O. Heating 9: N.C. Heating	6 and 7: Reheat 8: Open Heating 9: Closed Heating	6 and 7: Reheat 9: Proportional Heating
(4): Cool/Heat Four-Pipe	See Figure 18.	8: N.O. Heating 9: N.C. Heating 10: N.O. Cooling 11: N.C. Cooling	8: Open Heating 9: Closed Heating 10: Open Cooling 11: Closed Cooling	9: Proportional Heating 10: Proportional Cooling
(5): Cool/Heat Four-Pipe and Reheat	See Figure 19.	6 and 7: Reheat 8: N.O. Heating 9: N.C. Heating 10: N.O. Cooling 11: N.C. Cooling	6 and 7: Reheat 8: Open Heating 9: Closed Heating 10: Open Cooling 11: Closed Cooling	6 and 7: Reheat 9: Proportional Heating 10: Proportional Cooling

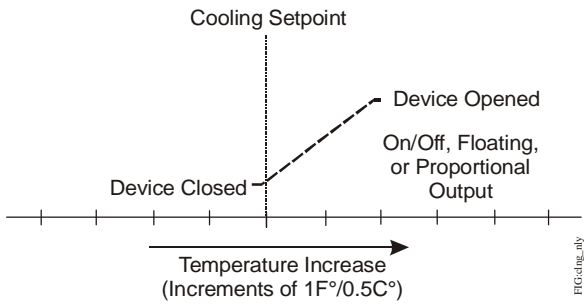

Figure 14: Cooling Only, Two- or Four-Pipe Applications

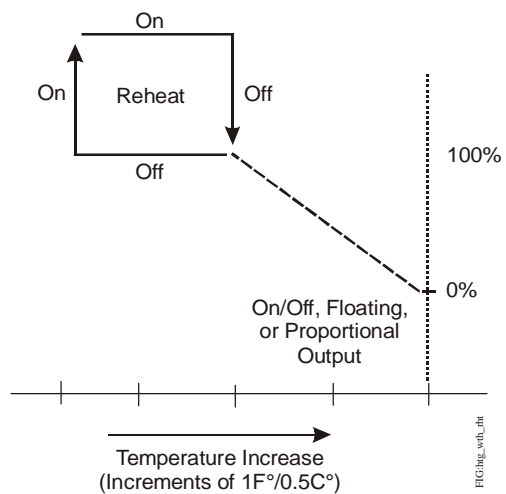

Figure 17: Heating with Reheat, Two- or Four-Pipe Applications

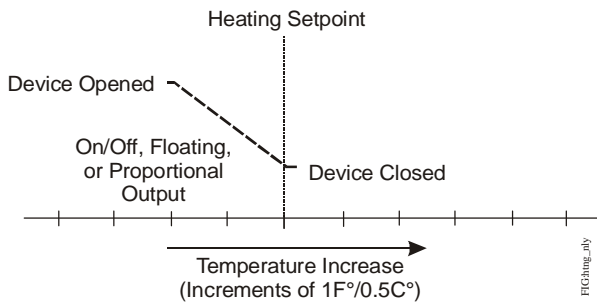

Figure 15: Heating Only, Two- or Four-Pipe Applications

———— Heating Output
 - - - - - Cooling Output

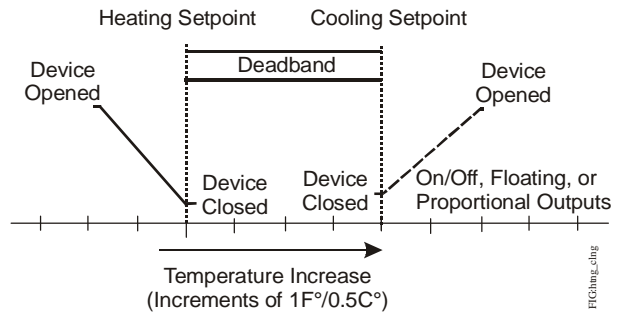

Figure 18: Heating/Cooling, Four-Pipe Applications

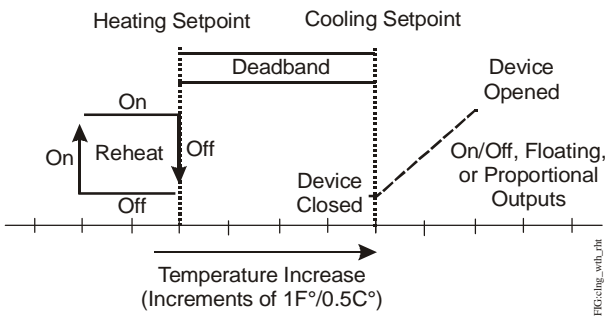

Figure 16: Cooling with Reheat, Two- or Four-Pipe Applications

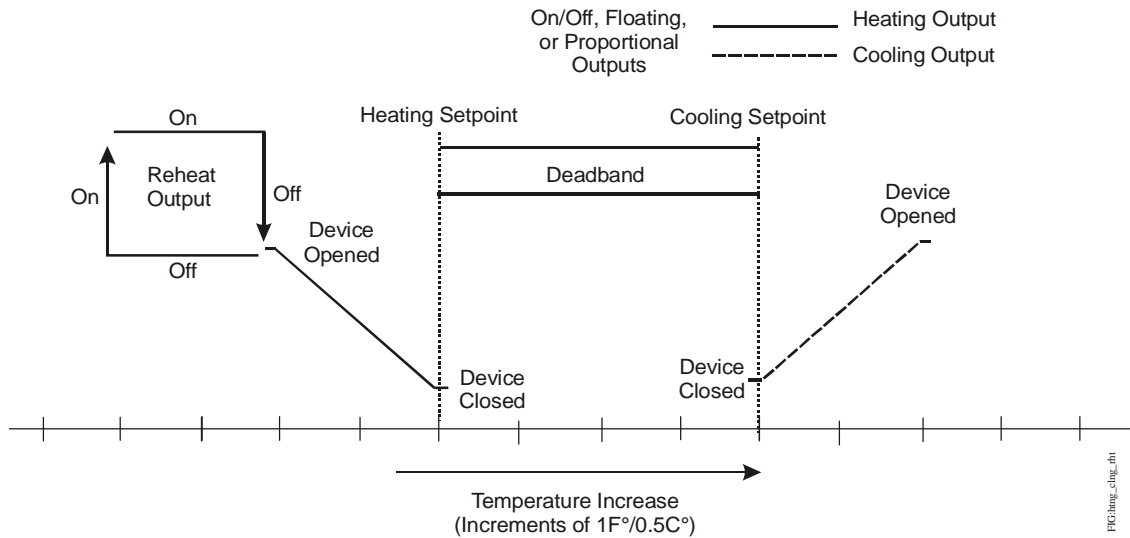

Figure 19: Heating/Cooling with Reheat, Four-Pipe Applications

Configuring Automatic Fan Speed

Use the **Fan Menu** parameter in the Installer Configuration Menu to set the available fan mode options. Use the **FAN** key to select the desired fan mode option.

When selection option **(2): Low-Med-High-Auto** is chosen in the **Fan Menu** parameter, the fan operates as shown in Figure 20. When selection option **(3): Low-High-Auto** is chosen in the **Fan Menu** parameter, the fan operates at only the low and high settings and ignores the medium setting (Figure 20). This operation applies to the Occupied mode when the fan is set to **Auto**.

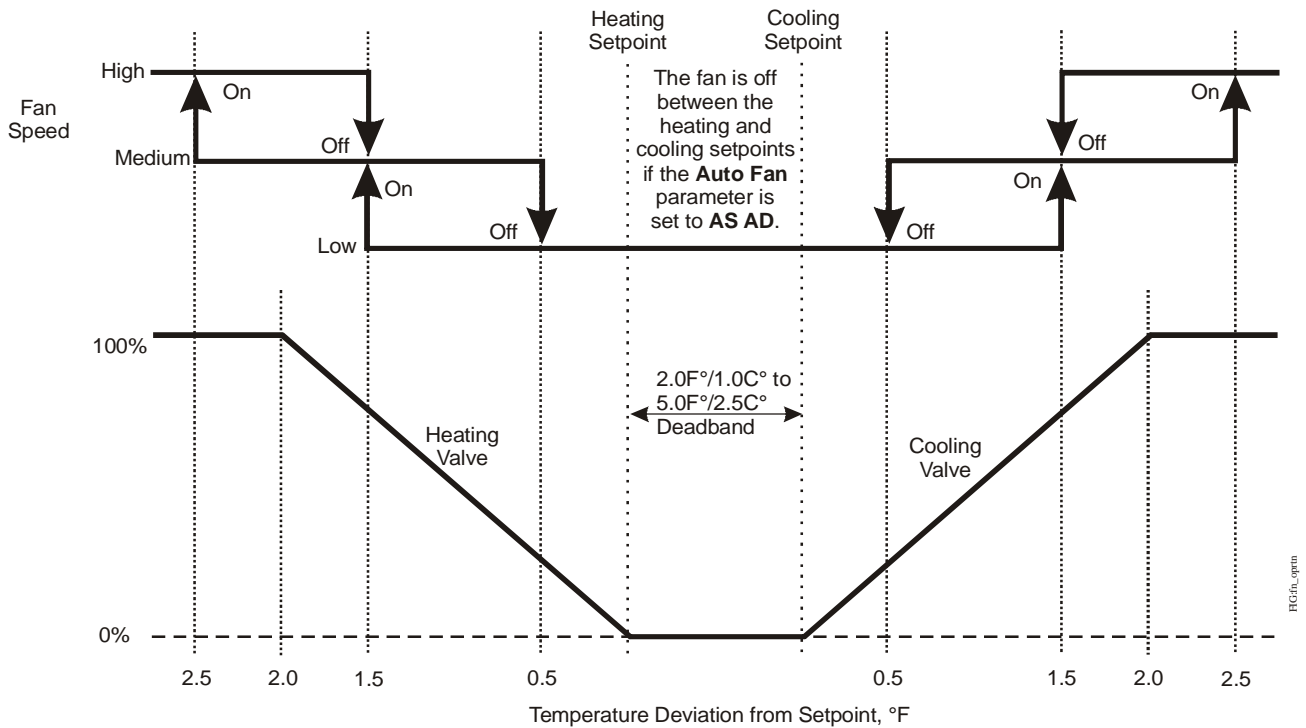

Figure 20: Low-Med-High-Auto and Low-High-Auto Fan Operation

Table 4: Installer Configuration Menu (Part 1 of 7)

Parameter Appearing on Display	Description and Default	Selection Options
Pswrd	Sets the protective access password to prevent unauthorized access to the Installer Configuration Menu. Default: 0 Note: The default setting does not lock out access to the Installer Configuration Menu.	Range: 0 to 1,000
BI1	Configuration of Binary Input 1. Default: None	<p>(None): No function is associated with an input.</p> <p>(Rem NSB): Remote Night Setback (NSB) via a time clock input, an occupancy sensor, or from a voltage-free contact. Contact open = Occupied; contact closed = Unoccupied.</p> <p>(MotionNO*): Temporary occupancy request via a motion detector input. Contact open = Unoccupied. When the contact closes, the thermostat controller goes into the Occupied mode for a specified TOccTime. Once the TOccTime begins, the thermostat controller remains in the Occupied mode if the contact is open, until the TOccTime expires. Advanced PIR occupancy functions using a Normally Open (N.O.) or Normally Closed (N.C.) remote PIR motion sensor.</p> <p>(MotionNC*): Temporary occupancy request via a motion detector input. Contact closed = Unoccupied. When the contact opens, the thermostat controller goes into the Occupied mode for a specified TOccTime. Once the TOccTime begins, the thermostat controller remains in the Occupied mode if the contact is closed, until the TOccTime expires. Advanced PIR occupancy functions using a Normally Open (N.O.) or Normally Closed (N.C.) remote PIR motion sensor.</p> <p>(Window): Cancels the thermostat controller heating or cooling action when a window is open. The fan operation is only affected if the Fan Menu parameter is set to (4): On-Auto, and Auto is the selected fan mode. A Window alarm is displayed indicating that the window needs to be closed to resume heating or cooling. The heating and/or cooling outputs are enabled only when the contact is closed.</p> <p>* These settings disable any local override function. For PIR models, see the <u>Occupancy Sensor Operation – T60xDFH-4+PIR Series Thermostat Controllers</u> section.</p>

Table 4: Installer Configuration Menu (Part 2 of 7)

Parameter Appearing on Display	Description and Default	Selection Options
BI2	Configuration of Binary Input 2. Default: None	<p>(None): No function is associated with an input.</p> <p>(Door Dry): Door contact only has an effect if BI1 is set to MotionNO or MotionNC or if a PIR accessory cover is used. (See the BI1 parameter earlier in this table.) The occupancy is now dictated via BI1, BI2, or PIR. Any motion detected sets the zone to Occupied status. The thermostat controller remains in the Occupied mode until the door contact switch opens momentarily, at which point the thermostat controller goes into Stand-By mode. If more movements are detected, the Occupied mode resumes. While the door is open, any movements detected by the PIR sensor are ignored. Use a Normally Closed (N.C.) switching device. (Contact open = door open; contact closed = door closed.)</p> <p>(RemOVR): Temporary occupancy request via a remote input. This override function is controlled by a manual remote occupancy override. When enabled, this condition disables the override capability of the thermostat controller.</p> <p>(Filter): A Filter alarm is displayed. This alarm can be connected to a differential pressure switch that monitors a filter.</p> <p>(Service): A Service alarm is displayed on the thermostat controller when the input is energized. This input can be tied into the air conditioning unit control card, which provides an alarm should there be a malfunction.</p>
UI3	Configuration of Universal Input 3. Default: None	<p>(None): No function is associated with an input.</p> <p>(COC/NH): Changeover Contact/Normally Heat: A dry contact input is used to signal seasonal hot/cold water changeover. The contact closes when cold water is present. Valid only for two-pipe systems.</p> <p>(COC/NC): Changeover Contact/Normally Cool: A dry contact input is used to signal seasonal hot/cold water changeover. The contact closes when hot water is present. Valid only for two-pipe systems.</p> <p>(COS): Changeover Analog Sensor: Used for hot/cold water changeover switching. Valid only for two-pipe systems. (Parameter Pipe No is set to 2.0.) If the water temperature is greater than 75°F/24°C, hot water is present. If the water temperature is less than 75°F/24°C, cold water is present.</p> <p>Note: Choose the selection option (0): Cooling Only for the SeqOpera parameter to allow changeover to occur between Cooling Only and Heating Only. The changeover sensor does not operate in Cooling and Reheat, Heating and Reheat, or Cool/Heat Four-Pipe and Reheat applications.</p> <p>(SS): Supply Air Sensor Monitoring</p>
MenuScro	Gives the option of having the display continuously scroll the parameters. Default: on	<p>(off): The scroll is inactive.</p> <p>(on): The scroll is active.</p>
AutoMode	Enables the auto function (if Option 2 is chosen in the SeqOpera parameter) to be visible within the MODE key menu. (The MODE key is the key at the far left of the thermostat controller cover.) Default: off	<p>(on): The auto function is active (Off-Auto-Heat-Cool). Provides automatic changeover between heating and cooling.</p> <p>(off): The auto function is inactive (Off-Heat-Cool).</p>
%RH disp	Displays the current humidity reading (T603 and T605 models). Default: off	<p>(on): Displays the current humidity reading in % RH.</p> <p>(off): Does not display the current humidity reading.</p>

Table 4: Installer Configuration Menu (Part 3 of 7)

Parameter Appearing on Display	Description and Default	Selection Options				
Lockout	Selectable Lockout Levels for limiting end-user keypad interaction. Default: 0	Lockout Level	Function			
			Mode Setting	Fan Setting	Local Override	Occupied Temperature Setpoints
		(0)	Access	Access	Access	Access
		(1)	Access	Access	No Access	Access
		(2)	No Access	No Access	Access	Access
		(3)	No Access	No Access	No Access	Access
		(4)	No Access	No Access	Access	No Access
(5)	No Access	No Access	No Access	No Access		
Pipe No	Selectable number of pipes in the system. Default: 4.0 Pipes	(2.0 Pipes): Limits the number of sequences of operation available from 0 to 3, and enables heat/cool operation from the same output. (4.0 Pipes): Allows access to all sequences of operation from 0 to 5, and enables heat/cool operation from different outputs.				
CntrlTyp	Defines the control output for the type of valves used in the installation (T602 and T603 models). Default: Floating	(On/Off): For Normally Open (N.O.) or Normally Closed (N.C.) 24 VAC two-position valves. (Floating): For three-wire control of 24 VAC floating valves.				
SeqOpera	Determines the sequence of operation. Default: 1	Sequence of Operation		Default Based on AutoMode Parameter Setting		
				On	Off	
		(0): Cooling Only (Off-Cool)		Cool	Cool	
		(1): Heating Only (Off-Heat)		Heat	Heat	
		(2): Cooling and Reheat (Off-Auto*-Heat-Cool)		Auto	Heat	
		(3): Heating and Reheat (Off-Heat)		Heat	Heat	
		(4): Cool/Heat Four-Pipe (Off-Auto*-Heat-Cool)		Auto	Heat	
(5): Cool/Heat Four-Pipe and Reheat (Off-Auto*-Heat-Cool)		Auto	Heat			
* Auto can be disabled with the AutoMode parameter. Note: Choose the selection option (0): Cooling Only when using a changeover sensor to allow changeover to occur between Cooling Only and Heating Only .						
Fan Menu	Sets the fan mode options. Default: 4	(0): Low-Med-High: Three-speed configuration using three fan relays (L-M-H). The default is High . (1): Low-High: Two-speed configuration using two fan relays (L-H). The default is High . (2): Low-Med-High-Auto: Three-speed configuration with Auto Fan speed mode using three fan relays (L-M-H). The default is High . (3): Low-High-Auto: Two-speed configuration with Auto Fan speed mode using two fan relays (L-H). The default is High . (4): On-Auto: One-speed configuration, (H) Auto is for Fan on demand and On is for Fan on all the time. The default is Auto .				
DHumiLCK	Locks out the dehumidification capability (T603 and T605 models). Default: on	(off): Dehumidification is locked out. (on): Dehumidification is allowed.				

Table 4: Installer Configuration Menu (Part 4 of 7)

Parameter Appearing on Display	Description and Default	Selection Options	
%RH set¹	Sets the dehumidification setpoints (T603 and T605 models). This parameter can be used only if the dehumidification sequence is enabled. Default: 50.0% RH	Range: 30.0 to 95.0% RH	
DehuHyst¹	Sets the dehumidification hysteresis (T603 and T605 models). This parameter can be used only if the dehumidification sequence is enabled. Default: 5.0% RH	Range: 2.0 to 20.0% RH	
DehuCool¹	Sets the maximum dehumidification cooling output (T603 and T605 models). This parameter can be used only if the dehumidification sequence is enabled. Default: 100%	Range: 20.0 to 100.0% Note: This parameter can be used to balance smaller reheat loads installed with regard to the capacity of the cooling coil.	
St-By TM	Sets the Stand-By timer value (PIR models). Default: 0.5 hours	Time delay between the moment the PIR cover detected the last movement in the area and the time at which the thermostat controller Stand-By mode and setpoints become active. Range: 0.5 to 24.0 hrs adjustable in 0.5-hour increments	
Unocc TM	Sets the Unoccupied timer value (PIR models). Default: 0.0 hours	Time delay between the moment the thermostat controller toggled to Stand-By mode and the time at which the thermostat controller Unoccupied mode and setpoints become active. Setting this parameter to the factory value (0.0 hours) disables the Unoccupied timer. This prevents the thermostat controller from switching from Stand-By mode to Unoccupied mode when PIR functions are used. Range: 0.0 to 24.0 hrs adjustable in 0.5-hour increments	
St-By HT	Sets the Stand-By heating setpoint (PIR models). Default: 69.0°F/20.5°C	The value of this parameter should reside between the Occupied and Unoccupied heating setpoints, and ensure that the difference between the Stand-By and Occupied value can be recovered in a timely fashion when movement is detected in the zone. Range: 40.0°F/4.5°C to 90.0°F/32.0°C	
St-By CL	Sets the Stand-By cooling setpoint (PIR models). Default: 78.0°F/25.5°C	The value of this parameter should reside between the Occupied and Unoccupied cooling setpoints, and ensure that the difference between the Stand-By and Occupied value can be recovered in a timely fashion when movement is detected in the zone. Range: 54.0°F/12.0°C to 100.0°F/37.5°C	
Unocc HT	Sets the Unoccupied heating setpoint value. Default: 62.0°F/16.5°C	Range: 40.0°F/4.5°C to 90.0°F/32.0°C	Note: When adjusting the temperature, press the UP/DOWN arrow keys to change the temperature in 0.5F°/0.5C° increments; press and hold the UP/DOWN arrow keys to change the temperature in 5.0F°/5.0C° increments.
Unocc CL	Sets the Unoccupied cooling setpoint value. Default: 80.0°F/26.5°C	Range: 54.0°F/12.0°C to 100.0°F/37.5°C	
Heat max	Sets the Occupied and Unoccupied maximum heating setpoint values. Default: 90.0°F/32.0°C	Range: 40.0°F/4.5°C to 90.0°F/32.0°C	
Cool min	Sets the Occupied and Unoccupied minimum cooling setpoint values. Default: 54.0°F/12.0°C	Range: 54.0°F/12.0°C to 100.0°F/37.5°C	

Table 4: Installer Configuration Menu (Part 5 of 7)

Parameter Appearing on Display	Description and Default	Selection Options
Pband	<p>Sets the proportional band used by the thermostat controller Proportional-Integral (PI) control loop. Default: 3.0F°/1.7C°</p> <p>Note: The proportional band default setting of 3.0F°/1.7C° provides satisfactory thermostat controller operation in most instances. A proportional band setting other than the default is normally used in installations where the location of the thermostat controller is problematic, leading to unwanted cycling. An example of a problematic installation is a wall-mounted thermostat controller installed between the return and supply air feeds, that is directly influenced by the supply air stream.</p>	<p>(3): 3.0F°/1.7C° (4): 4.0F°/2.2C° (5): 5.0F°/2.8C° (6): 6.0F°/3.3C° (7): 7.0F°/3.9C° (8): 8.0F°/4.4C° (9): 9.0F°/5.0C° (10): 10.0F°/5.6C°</p>
Set type	<p>Provides the option of temporarily changing the heating or cooling setpoint by pressing the UP/DOWN arrow keys. Default: permanent</p>	<p>(temporar): Local changes to the heating or cooling setpoints are temporary, and remain effective for the specified TOccTime. (permanent): Local changes to the heating or cooling setpoints are permanently stored in the thermostat memory.</p>
Spt Func	<p>Determines the operation and usage of the local setpoint interface by the user. Default: Dual Stp</p>	<p>(Attch Stp): Single Occupied Setpoint Adjustment. The displayed setpoint is the setpoint from the last action taken by the thermostat controller, or the setpoint currently in use. Both the heating and cooling setpoints are changed simultaneously, while respecting the minimum configured deadband. If one setpoint is desired over the other, use the MODE key to toggle between the two setpoints. (Dual Stp): Dual Occupied Setpoint Adjustment. The displayed setpoint is the setpoint from the last action taken by the thermostat controller, or the setpoint currently in use. The heating and cooling setpoints can be separated individually, allowing the minimum configured deadband to expand. If one setpoint is desired over the other, use the MODE key to toggle between the two setpoints.</p>
TOccTime	<p>Sets the duration of the Temporary Occupancy Time when the heating or cooling setpoints in the Occupied mode are established by:</p> <ul style="list-style-type: none"> • an override function enabled from a remote override (when the thermostat controller is in the Unoccupied mode) • a temporary heating or cooling setpoint <p>Default: 2.0 hrs</p>	<p>Range: 0.0 to 24.0 hrs adjustable in 1-hour increments</p>
Deadband	<p>Sets the minimum deadband between the heating and cooling setpoints. Default: 2.0F°/1.0C°</p>	<p>Range: 2.0F°/1.0C° to 5.0F°/2.5C° adjustable in 1.0F°/0.5C° increments</p>

Table 4: Installer Configuration Menu (Part 6 of 7)

Parameter Appearing on Display	Description and Default	Selection Options			
Cal RS	Sets the desired room air temperature sensor calibration (offset). The offset can be added to or subtracted from the actual displayed room temperature. Default: 0.0F°/0.0C°	Range: -5.0F°/-2.5C° to 5.0F°/2.5C° adjustable in 1.0F°/0.5C° increments			
Cal RH	Sets the desired humidity sensor calibration (offset). The offset can be added to or subtracted from the actual displayed room humidity (T603 and T605 models). This parameter can be used only if the dehumidification sequence is enabled. Default: 0.0% RH	Range: -15.0% RH to 15.0% RH adjustable in 1% RH increments			
Aux cont	Determines the auxiliary contact function and configuration. Default: 0	(0)	Not used, or used for reheat	If the sequence of operation is set to reheat (2, 3, or 5), ignore this parameter.	
		(1)	Auxiliary N.O.	Occupied = contact closed Unoccupied = contact open	The output aligns with occupancy.
		(2)	Auxiliary N.C.	Occupied = contact open Unoccupied = contact closed	
		(3)	Auxiliary N.O.	Occupied and fan On = contact closed Unoccupied and fan On or Off = contact open	The output aligns with occupancy and the fan on command.
		(4)	Auxiliary N.C.	Occupied and fan On = contact open Unoccupied and fan On or Off = contact closed	
		Note: The contact toggles with the Occupied/Unoccupied schedule of the NSB contact on B11, if used.			
Auto Fan	Affects the auto mode of operation for the following Fan Menu parameter selection options only: <ul style="list-style-type: none"> (2): Low-Med-High-Auto (3): Low-High-Auto Default: AS	<p>(AS AD): The fan is on Auto during occupied periods. The Med and High speeds operate automatically on a temperature error from the setpoint. The Low speed operates Auto on demand. When there is no demand, the Low speed shuts down. The Low speed is only re-activated when there is a heating or cooling demand.</p> <p>(AS): The fan is always on during occupied periods. The fan is on Auto during unoccupied periods. The Low, Med, and High speeds operate automatically on a temperature error from the setpoint.</p>			
FL time	Sets the maximum actuator stroke timing (floating CntriTyp T602 and T603 models). Default: 1.5 min	Range: 0.5 to 9.0 min adjustable in 0.5-minute increments			
Cph	Sets the maximum number of cycles per hour (T601 and on/off CntriTyp T602 and T603 models). Default: 4.0	Range: 3.0 to 8.0 cycles per hour			

Table 4: Installer Configuration Menu (Part 7 of 7)

Parameter Appearing on Display	Description and Default	Selection Options
RA/DA	Choice of reverse or direct acting analog output signal (T604 and T605 models) Default: DA	(RA): Reverse acting, 0 to 100% = 10 to 0 VDC (DA): Direct acting, 0 to 100% = 0 to 10 VDC
Reheat	Sets the duty cycle time for reheat output (if Option 2, 3, or 5 is chosen in the SeqOpera parameter). Default: 0	(1): 10 seconds (six cycles per minute), for various equipment with solid-state relays that withstand short duty cycles such as electric heat. (0): 15 minutes (four cycles per hour), for various equipment with mechanical relays or contactors controlling mechanical reheat systems.
UI3 dis	Displays the supply or changeover temperature when UI3 is configured as an analog input (supply sensor or changeover sensor). Default: -40°F/-40°C	Used as a diagnostic/service help, to troubleshoot and diagnose sensor operation.

1. When adjusting the numeric value, press the **UP/DOWN** arrow key to change the value by single increments; press and hold the **UP/DOWN** arrow key to change the numeric value in increments of ten.

Accessories

All the accessories in Table 5 include mounting hardware; contact the nearest Johnson Controls® representative to order any of these parts.

Note: Review the technical specifications of the accessories prior to their use in an application.

Repair Information

If the T60xDFH-4 or T60xDFH-4+PIR Series Thermostat Controller fails to operate within its specifications, replace the unit. For a replacement thermostat controller, contact the nearest Johnson Controls representative.

Table 5: Accessories (Order Separately)

Code Number	Description
SEN-600-1	Remote Inside Air Temperature Sensor
TE-6361M-1¹	Duct Mount Air Temperature Sensor
TE-636S-1¹	Strap-Mount Temperature Sensor
TEC-6H-PIR²	Cover with Occupancy Sensor

1. Additional TE-636xx-x Series 10k ohm Johnson Controls Type II Thermistor Sensors are available; refer to the *TE-6300 Series Temperature Sensors Product Bulletin (LIT-216320)* for more details.
2. The TEC-6H-PIR Accessory Cover can be used to replace the existing cover on a non-PIR T60xDFH-4 Series Thermostat Controller to provide occupancy sensing capability.

Table 6: Display Messages

Display	Function
Service	Indicates that there is a service alarm in accordance with the programmable Binary Input (BI2).
Filter	Indicates that the filter(s) is dirty in accordance with the programmable Binary Input (BI2).
Window	Indicates that an outside window or door is open and has cancelled the thermostat controller heating or cooling action in accordance with the programmable Binary Input (BI1).

Technical Specifications

T60xDFH-4 and T60xDFH-4+PIR Series Thermostat Controllers with Dehumidification and Occupancy Sensing Capability

Power Requirements		19 to 30 VAC, 50/60 Hz, 2 VA (Terminals 4 and 5) at 24 VAC Nominal, Class 2 or Safety Extra-Low Voltage (SELV)
Relay/Triac Contact Rating	On/Off and Floating Control	30 VAC, 1.0 A Maximum, 15 mA Minimum, 3.0 A Inrush, Class 2 or SELV
Analog Output Rating	Proportional Control	0 to 10 VDC into 2k ohm Resistance (Minimum)
Fan Relay Output Rating		19 to 30 VAC, 1.0 A Maximum, 3.0 A Inrush
Auxiliary Output Rating	Triac Output	19 to 30 VAC, 1.0 A Maximum, 3.0 A Inrush
Digital Inputs		Voltage-Free Contacts across Terminal Scom to Terminals BI1, BI2, or UI3
Analog Inputs		Resistive Inputs (RS and UI3) for 10k ohm Johnson Controls Type II Negative Temperature Coefficient (NTC) Thermistor Sensors
Temperature Sensor Type		Local 10k ohm Johnson Controls Type II NTC Thermistor Sensor
Wire Size		18 AWG (1.0 mm Diameter) Maximum, 22 AWG (0.6 mm Diameter) Recommended
Temperature Range	Backlit Display	-40.0°F/-40.0°C to 122.0°F/50.0°C in 0.5° Increments
	Heating Control	40.0°F/4.5°C to 90.0°F/32.0°C
	Cooling Control	54.0°F/12.0°C to 100.0°F/38.0°C
Accuracy	Temperature	±0.9F°/±0.5C° at 70.0°F/21.0°C Typical Calibrated
	Humidity	±5% RH from 20 to 80% RH at 50 to 90°F (10 to 32°C)
Minimum Deadband		2F°/1C° between Heating and Cooling
Ambient Conditions	Operating	32 to 122°F (0 to 50°C); 95% RH Maximum, Noncondensing
	Storage	-22 to 122°F (-30 to 50°C); 95% RH Maximum, Noncondensing
Compliance	United States	UL Listed, File E27734, CCN XAPX, Under UL 873, Temperature Indicating and Regulating Equipment
		FCC Compliant to CFR 47, Part 15, Subpart B, Class A
	Canada	UL Listed, File E27734, CCN XAPX7, Under CAN/CSA C22.2 No. 24, Temperature Indicating and Regulating Equipment
		Industry Canada, ICES-003
	Europe	CE Mark, EMC Directive 2004/108/EC
Australia and New Zealand	C-Tick Mark, Australia/NZ Emissions Compliant	
Shipping Weight	T60xDFH-4 Models	0.75 lb (0.34 kg)
	T60xDFH-4+PIR Models	0.77 lb (0.35 kg)

The performance specifications are nominal and conform to acceptable industry standards. For application at conditions beyond these specifications, consult the local Johnson Controls office. Johnson Controls, Inc. shall not be liable for damages resulting from misapplication or misuse of its products.



Building Efficiency

507 E. Michigan Street, Milwaukee, WI 53202

Metasys® and Johnson Controls® are registered trademarks of Johnson Controls, Inc. All other marks herein are the marks of their respective owners. © 2009 Johnson Controls, Inc.